

INTEWA
Ingenieurgesellschaft
für Energie- und Was-
sertechnik mbH

**FILTER COMPARISION TEST
BETWEEN INTEWA HYDRAULIC JUMP FILTER WSP
100,
3P CARTRIDGE FILTER PF AND WISY FINE SWIRL
FILTER WFF-100**

Contractor: INTEWA Ingenieurgesellschaft
für Energie- und Wassertechnik mbh
Jülicher Str. 336
52070 Aachen

Order dated: 17.06.2002

Order No.: WBL 167 D

Installed at: Forschungsstelle Wasserwirt-
schaft und Umwelt fwu at the
Siegen University

Prof. Dr. Eng. Jürgen Jensen
B. Sc. (University of Applied Sci-
ences) Jörg Wieland

Siegen, on 02.08.2002

Table of contents

1	Background and scope of work	1
2	Experimental setup	Fehler! Textmarke nicht definiert.
3	The results of comparison tests of the rainwater filter	2
3.1	INTEWA hydraulic jump filter WSP 100	2
3.1.1	Description of the manufacturer	Fehler! Textmarke nicht definiert.
3.1.2	Result of the Filter comparison test	3
3.2	3P cartridge filter PF	4
3.2.1	Description of the manufacturer	Fehler! Textmarke nicht definiert.
3.2.2	Result of the filter comparison test	5
3.3	WISY Fine swirl filter WFF-100 with 440 μm Filter insert	7
3.3.1	Description of the manufacturer	Fehler! Textmarke nicht definiert.
3.3.2	Result of the filter comparison test	8
4	Summary	Fehler! Textmarke nicht definiert.
5	Literature	Fehler! Textmarke nicht definiert.
6	Annexure	14

List of figures

Figure 1:	Experimental setup for the filter comparison test of the rainwater filter	1
Figure 2:	Thompson slope $Q = 0.1 \text{ l/s}$	2
Figure 3:	INTEWA Hydraulic jump filter WSP100	2
Figure 4:	INTEWA Hydraulic jump filter WSP100 with $Q = 0.1 \text{ l/s}$	3
Figure 5:	INTEWA Hydraulic jump filter WSP100 with $Q = 0.2 \text{ l/s}$	3
Figure 6:	INTEWA Hydraulic jump filter WSP100 with $Q = 0.2 \text{ l/s}$ with dirt	4
Figure 7:	(left) 3P cartridge filter PF	4
Figure 8:	(right) Functioning principle of 3P cartridge filter PF	4
Figure 9:	Functioning principle of backflushing automatic 3P cartridge filter PF	5
Figure10:	(left) 3P cartridge filter PF with $Q = 0.1 \text{ l/s}$	5
Figure 11:	(right) 3P cartridge filter PF with $Q = 0.2 \text{ l/s}$ (5 sec after beginning of test)	6
Figure 12:	(left) 3P cartridge filter PF with $Q = 0.2 \text{ l/s}$ and dirt (leaves)	6
Figure 13:	(right) 3P cartridge filter PF with $Q = 0.2 \text{ l/s}$ and dirt (leaves)	6
Figure 14:	(left) 3P cartridge filter PF mit $Q = 0.2 \text{ l/s}$ and dirt (paper)	7
Figure 15:	(right) 3P cartridge filter PF with $Q = 0.2 \text{ l/s}$ and dirt (paper) – close-up view	7
Figure 16:	(left) WISY Fine Swirl Filter WFF-100	7
Figure 17:	(right) Functioning principle of WISY Fine Swirl Filter WFF-100	7
Figure 18:	(left) WISY WFF-100 with $Q = 0.1 \text{ l/s}$ (from beginning of the test)	9
Figure 19:	(right) WISY WFF-100 with $Q = 0.1 \text{ l/s}$ (towards end of the test)	9
Figure 20:	(left) WISY WFF-100 with $Q = 0.2 \text{ l/s}$ (from beginning of the test)	9
Figure 21:	(right) WISY WFF-100 with $Q = 0.1 \text{ l/s}$ (towards end of the test)	9
Figure 22:	(left) WISY Fine swirl Filter with dirt (leaves)	9
Figure 23:	(right) WISY Fine swirl filter with dirt (leaves)	9

List of tables

Table 1:	Evaluation of rainfall data from year 1993 to 1997	10
Table 2:	Numerical example of input data for estimation of annual loss of water quantity	12
Table 3:	Result of numerical example for estimation of annual loss of water quantity	12
Table 4:	Result of filter comparison test	14

1 Background and scope of work

INTEWA Ingenieurgesellschaft für Energie- und Wassertechnik mbH) Aachen, has authorized the Forschungsstelle Wasserwirtschaft und Umwelt (fwu) at the university of Siegen, on 17.06.2002, to carry out a filter comparison test with the following rainwater filters:

- 3P cartridge filter PF
- INTEWA Hydraulic jump filter WSP 100
- WISY Fine swirl filter WFF-100 with 440 μm Filter insert

2 Experimental setup

The operational behaviour has to be tested for the nominal width DN 100 of the above mentioned rainwater filters. In total, three series of tests were conducted:

1. Uncontaminated filter with $Q = 0.1 \text{ l / s}$
2. Uncontaminated filter with $Q = 0.21 \text{ l / s}$
3. Dirty filter with $Q = 0.21 \text{ l / s}$

The dirt in the third series of tests consisted of leaves and paper, as a substitute for foliage (each piece of approx. 5 by 5 cm totalling 90 g/m²). For analyzing the rainwater filter, the test arrangement was made as per Figure 1 in the Forschungsstelle Wasserwirtschaft und Umwelt (fwu) experimental hall at the University of Siegen. The water intake, operated by a circuit, produced simulated rainfall events of varying intensities. Here, the rain water was supplied from a processed water source from the water tower, and therefore was capable of being continuously supplied up to 2.0 l/s.

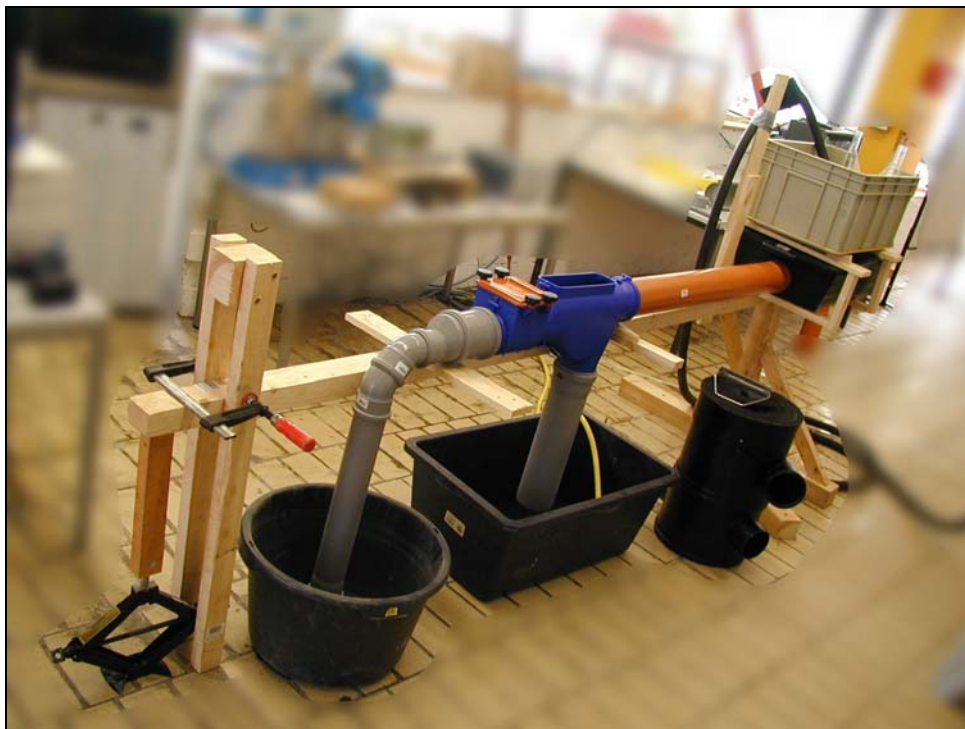

Figure 1: Experimental setup for filter comparison test of rainwater filter



The test was carried out at 0.1 l/s and 0.2 l/s. The amount of water intake was set with the help of a Thompson slope (see Figure 2). The connection of the inlet and outlet pipes was easily done, but we recommend that before assembling the lip seals, you should lubricate them with a lubricant on a soap base.

Figure 2: Thompson slope with $Q = 0.1$ l/s

3 Result of the comparison test of rainwater filter

3.1 INTEWA Hydraulic jump filter WSP 100

3.1.1 Description of the manufacturer

Following details of INTEWA Hydraulic Jump Filter WSP100, illustrated in the Figure 3 is extracted from <http://www.intewa.de> (Manufacturer):

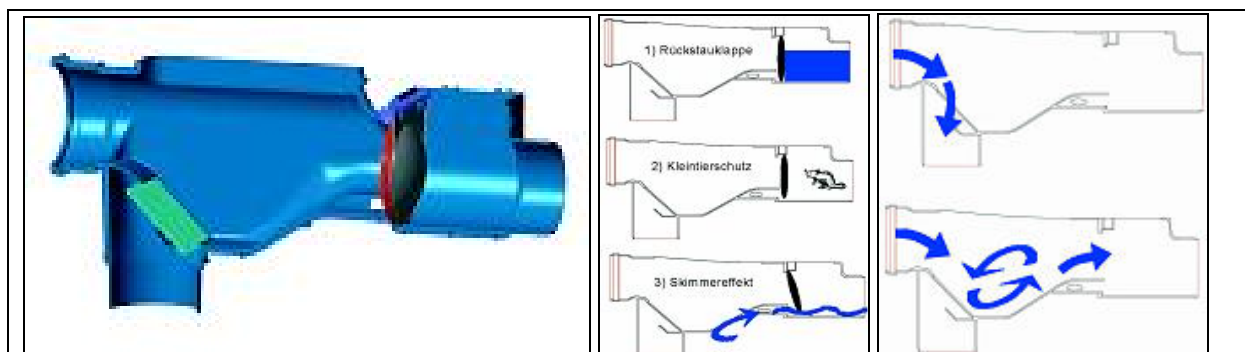

Figure 3: INTEWA Hydraulic Jump filter WSP100

Self-cleaning rainwater filter for installation in the cistern with an effective overall efficiency of > 97 % and very low height offset. Suitable for roof areas from 50 to max. 300 m². Very low maintenance due to self cleaning with hydraulic jump effect. Stainless steel wedge wire sieve with 0.4 mm gap width. Integrated non-return valve according to DIN 1989 Part 1, which also takes over the function of protection from small animals as well as a built-in overflow skimmer for extracting floating pollutants with each overflow

Technical Data: Inlet: DN 100 (pipe collar) dirty water drainage: DN 100 (pointed end) discharge to the cistern: DN 100 stainless steel wedge wire sieve with 0.4 mm gap width Housing material: PP dimensions (L×W×D): 604 × 180 × 290 mm height offset between inlet and dirty water drain: 47 mm

3.1.2 Result of filter comparison test

As per the test, the INTEWA hydraulic jump filter DN 100 with $Q = 0.1 \text{ l/s}$ (see Figure 4) filters the inflow up to 100 %; there is no overflow.

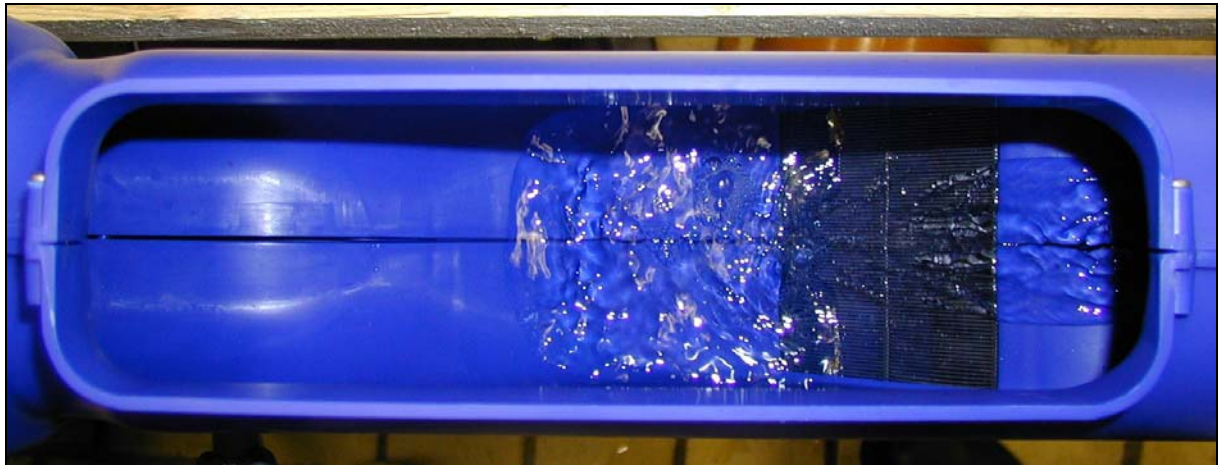

Figure 4: INTEWA Hydraulic jump filter WSP100 with $Q = 0.1 \text{ l/s}$

Even the startup behaviour with $Q = 0.2 \text{ l/s}$ delivered the same result for the INTEWA Hydraulic jump filter DN 100 (see Figure 5), filters the inlet up to 100 % and there was no overflow.



Figure 5: INTEWA Hydraulic jump filter WSP100 with $Q = 0.2 \text{ l/s}$

In the same way, the INTEWA hydraulic jump filter DN 100 at $Q = 0.2 \text{ l/s}$ worked with dirt (see Figure 6). The inlet was filtered up to 100 % and there was no overflow. The test with paper revealed no differences to the test with leaves. The filter was cleaned during heavy rainfall by means of the hydraulic jump; the dirt was swirled up and flushed out. If the dirt was not flushed out completely, the INTEWA hydraulic jump filter DN 100 still worked 100 %, because neither the position of, nor the type of dirt, lead to the deterioration in the level of efficiency.



Figure 6: INTEWA Hydraulic jump filter WSP100 with $Q = 0.2$ l/s with contaminant

3.2 3P Cartridge filter PF

3.2.1 Description of the manufacturer

The following specifications illustrating the description of the 3P cartridge filter PF mentioned in Figure 7 and Figure 8 are extracted from <http://www.3ptechnik.de/> (Manufacturer):



Figure 7: (left) 3P cartridge filter PF

Figure 8: (right) Functioning principle of 3P cartridge filter PF

1. The rainwater is directed in the filter cartridge (DN 100).
2. The filter cartridge cleans the rainwater, the cleaned water is directed in the rainwater storage via the quiet intake (DN 100).
3. The filtered dirt is flushed in the drainage system (DN 100) by inclination and smooth surface structure of the sieve (DN 100).

Rainwater filter for roof areas up to 150 m² for installation in rainwater storage. By slight inclination of the sieve cartridge, the dirt is flushed into the drainage system and requires extremely low maintenance. Sieve cartridge made from stainless steel with plastic coating. The 3P cartridge filter can be retrofitted with the 3P backflushing device. Height difference between inlet and outlet is 66 mm.

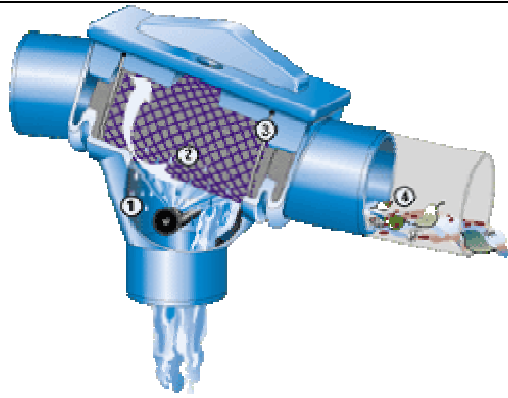

Figure 9: Functional principles of the backflushing automatic system of 3P cartridge filter PF

1. If the backflushing mechanism is activated, then the nozzle sprays in an angle from below the sieve cartridge.
2. The stream of water infiltrates the sieve screen and removes any impurities from it.
3. The stream of water activates the filter cartridge and puts it in a rotating motion. In this way, the entire sieve screen of the filter cartridge is cleaned.
4. The dirty water is flushed in the drainage system.

3.2.2 Result of filter comparison test

According to the tests, the 3P cartridge filter with $Q = 0.1$ l/s (see Figure 10) filtered the inlet to about 99 %. With the dry sieve, the overflow takes place in the first few seconds, then decreases up until the loss of droplets. After approx. 28 min, there was no more loss, the total quantity amounted to approx. 630 ml. At $Q = 0.2$ l/s (see Figure 11), the 3 P cartridge filter PF filtered the inlet to almost 100 %. The stronger overflow took place only in the first few seconds, after that there was no further loss.

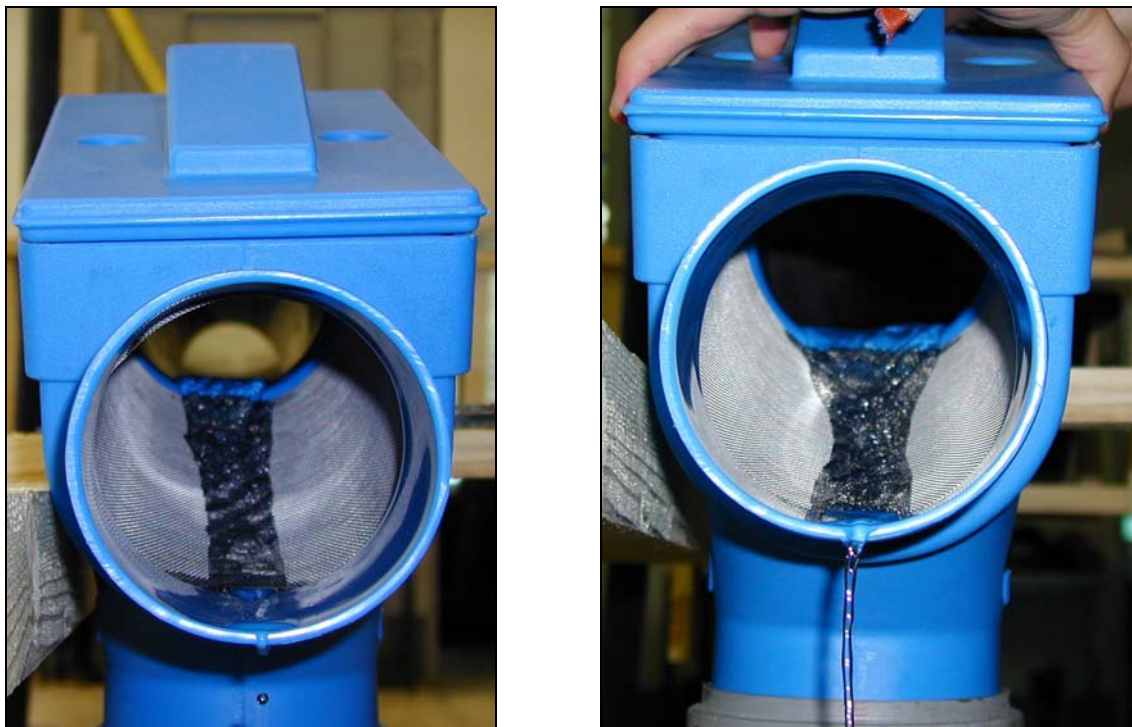

Figure 10: (left) 3P cartridge filter PF with $Q = 0.1$ l/s

Figure 11: (right) 3P cartridge filter PF with $Q = 0.2 \text{ l/s}$ (5 sec after beginning of test)

If more dirt was added to the experiment with $Q = 0.2 \text{ l/s}$, then the filter performance of the 3P cartridge filter PF decreased. Depending on the position of the dirt, only the droplets were lost (see Figure 12), whereby a filter performance of almost 100 % was obtained, with a constant flow loss of $Q_{\text{ver}} \approx 0.01 \text{ l/s}$ (see Figure 13), wherein the filter performance was reduced to about 95 %. In Figure 12 and Figure 13, exactly the same leaves can be seen, only their position within the filter is different. This means that simply the position of the dirt may reduce the efficiency of the filter. The inappropriate position of the dirt, and thereby resulting maximum loss of water, is difficult to determine with these leaves. Smaller leaves (such as from a Birch tree) lead to higher losses when they are soaked. In order to ensure complete tracking of the tests, 90 g/m^2 of paper was used as a substitute for leaves.



Figure 12: (left) 3P Cartridge filter PF with $Q = 0.2 \text{ l/s}$ and dirt (Leaves)

Figure 13: (rechts) 3P Cartridge filter PF with $Q = 0.2 \text{ l/s}$ and dirt (Leaves)

In the following tests with $Q = 0.2 \text{ l/s}$, the dirt was simulated (see Figure 14 and Figure 15) with paper of a size approximately 5 by 5 cm, rather than with leaves. If the filter performance of the 3P cartridge filter PF decreased, then a constant loss of $Q_{\text{ver}} \approx 0.11 \text{ l/s}$ is determined that corresponds to a filter performance of approx. 44 %. You can remove the dirt only manually, or with a heavy rainfall, when no extra backflushing device (see 3.2.1) is installed. This can lead to significant loss of water if the filter is not cleaned often enough. The backflushing device is battery operated and must be checked for proper functioning, since additional water can be lost due to irregular backflushing.

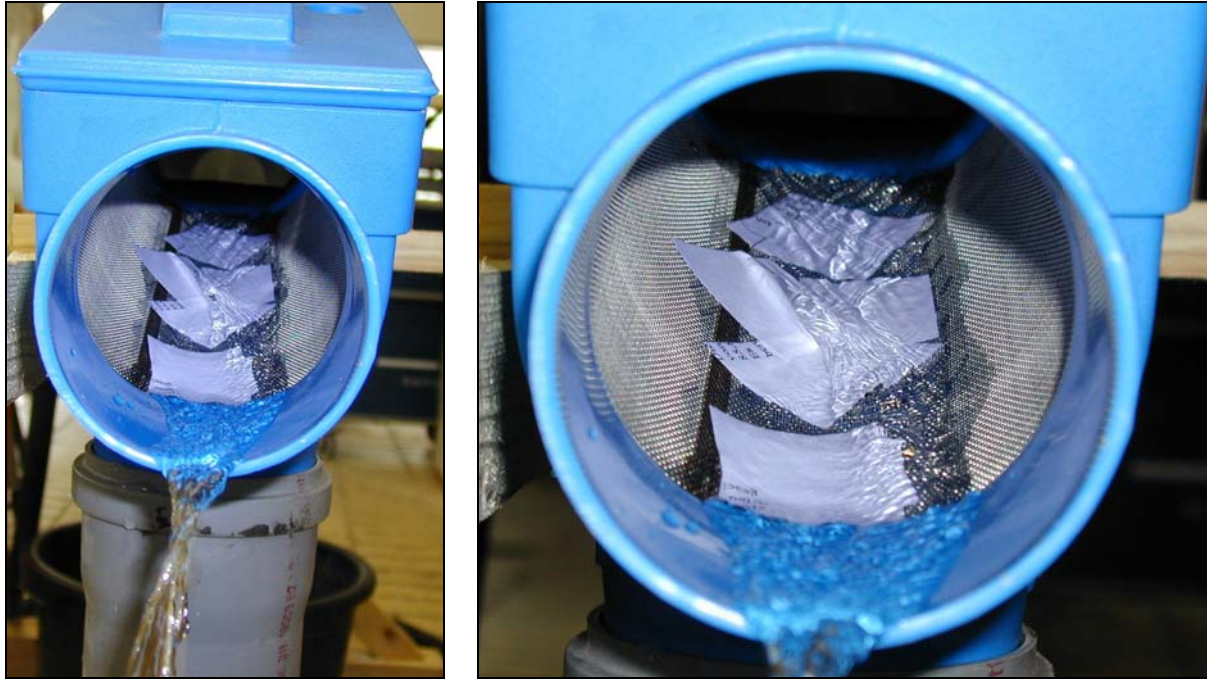

Figure 14: (left) 3P cartridge filter PF with $Q = 0.2 \text{ l/s}$ and dirt (Paper)

Figure 15: (right) 3P cartridge filter PF with $Q = 0.2 \text{ l/s}$ and dirt (Paper) - close up view

3.3 WISY Fine swirl filter WFF-100 with $440 \mu\text{m}$ Filter insert

3.3.1 Description of the manufacturer

Following specifications describing the WISY Fine Swirl Filter WFF-100 with $440 \mu\text{m}$ filter insert illustrated in figure 16 and figure 17 is extracted from <http://www.wisy.de> (Manufacturer):

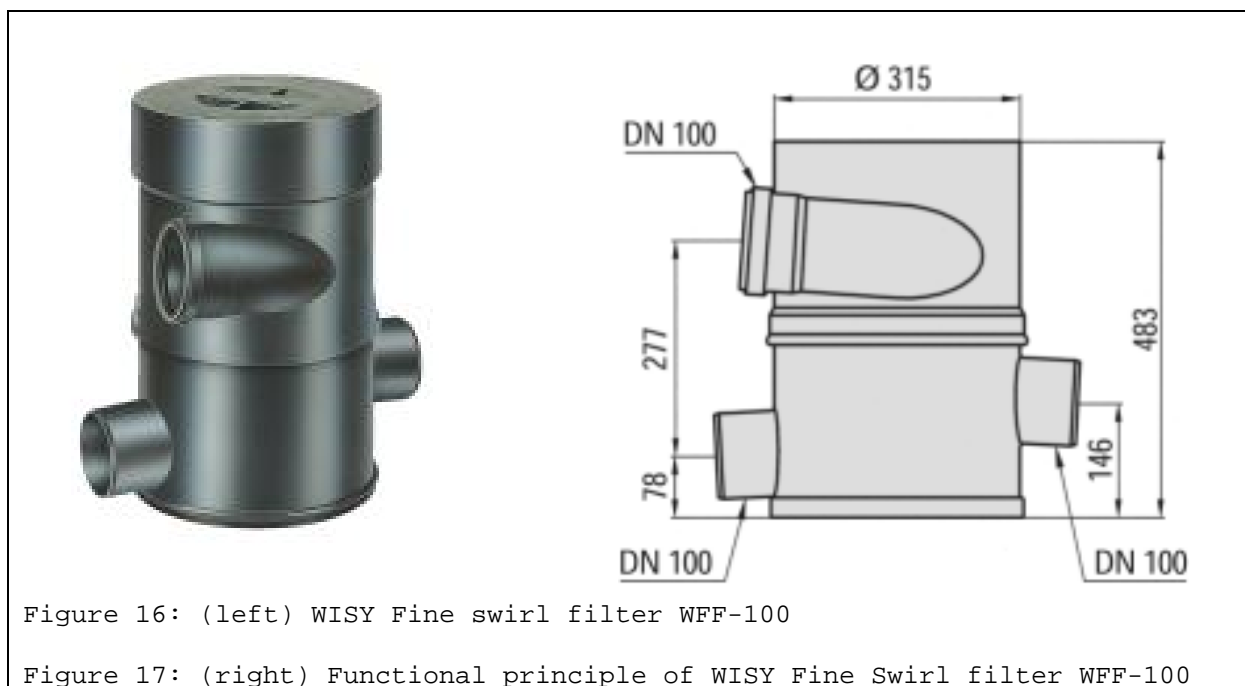

Figure 16: (left) WISY Fine swirl filter WFF-100

Figure 17: (right) Functional principle of WISY Fine Swirl filter WFF-100

The WISY Fine Swirl Filter, hereafter called as WFF is designed for underground installation. There it is connected to a horizontal rainwater drainage pipe and filters the water from roof area which is then directed to a storage. The sloping roofs made of shale, clay bricks or concrete tiles are the most preferable roofs suitable as roof areas. The planted roof areas have only limited suitability due to their low water yield. Roofs with roofing cardboards are also not recommended. Unsealed asbestos cement roofs are not suitable. The washed fibers of this roof covers clog the fine filter mesh.

The WFF filters the run-off water from the roof to a horizontal discharge pipe which is then connected to a storage. The rainwater coming from the roof runs into the sides of the WFF and is directed in a wide area via the cylindrical filter mesh. Here the run-off water from the roof is drawn through the vertically placed fine filter by utilizing the adhesion force and is directed to the storage contained via discharge port, whereas the dirt along with the remaining water is flushed to the drainage. According to this principle, more than 90 % of the rainwater infiltrating in the WFF is filtered. The open cross-sections of the roof drainage pipes continuously remain in the WFF. There are no cross-sectional obstructions in the device, where dirt and water can accumulate. This is particularly important with torrential rains containing heavy water input. In such cases, 50 % of the filtered water is directed to the storage tank. Excess rainwater is directly led to the drainage system. The filter mesh virtually cleans itself cleaning, since virtually nothing to the vertical mesh can get caught. As the collecting area are preferably inclined roofs of slate, clay or concrete tiles. Planted roof areas are due to their low water yield for computation. Unsealed asbestos cement roofs are not suitable. These asbestos roofs are not only a threat to the environmental and health, even the washed fibers that settle on the roof and even on the fine filter mesh of up to 200 m² roof area.

The housing of the WFF is maintenance free. It consists of rot-proof plastic. The filter cartridges do not require much maintenance, but however are not completely maintenance free. The filter mesh of the filter cartridge cleans itself to a large extent, since all coarse dirt particles fall on the vertical mesh. Nevertheless, with the course of time due to environmental influences, a thin, dark-coloured concentration builds up which reduces the performance of the filter and makes cleaning necessary (differs from region to region). In worst cases, cleaning may be necessary at shorter time intervals, in others only after half a year. By then you should clean the filter in any case by the use of a high pressure cleaner (available at many car washing sites). In many cases it has been proved that cleaning is done in the dishwasher, but it can also be done by hand using a small brush and a commercial detergent.

3.3.2 Result of filter comparison test

As per the tests, the WISY fine swirl filter WFF-100 at $Q = 0.1$ l/s filters the inflow to about 75 %. The loss is greater at the beginning (see Figure 18), but steadily decreases (see Figure 19). After approx. 60 min, the test was concluded and the amount of water loss was approx. 90 l. If the sieve is wet at the beginning of the test, then almost 100 % of the inflow is filtered.



Figure 18: (left) WISY WFF-100 with $Q = 0.11/s$ (till the beginning of the test)

Figure 19: (right) WISY WFF-100 with $Q = 0.11/s$ (up till the end of the test)

At $Q = 0.21/s$ (see Figure 20), the WISY fine swirl filter WFF-100 filtered the inflow only about 53 %. **90 l of water was lost during the first 16 mins** (see Figure 21).

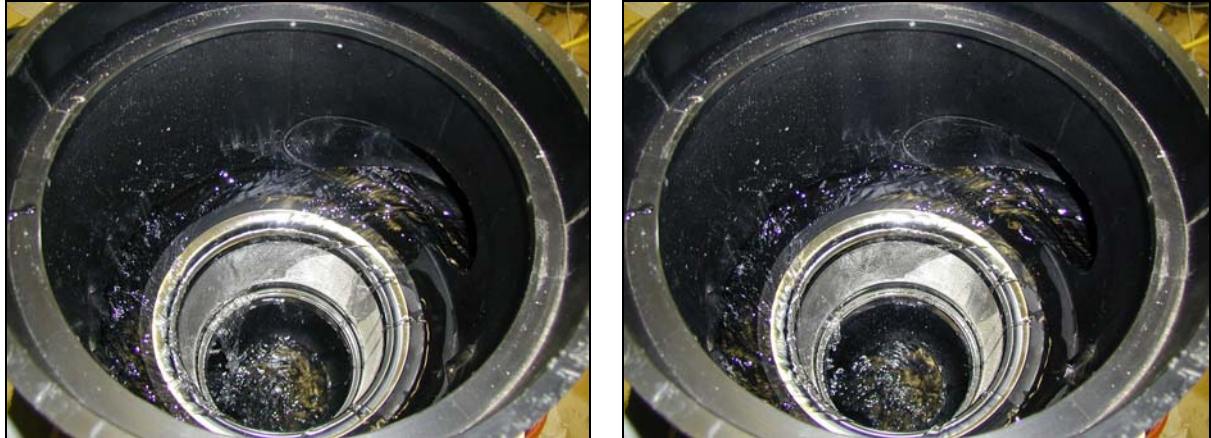

Figure 20: (left) WISY WFF-100 with $Q = 0.21/s$ (at the beginning of test)

Figure 21: (right) WISY WFF-100 with $Q = 0.11/s$ (at the end of the test)

The performance of the WISY fine swirl filter WFF-100 showed only a very small decrease in the level of efficiency with dirt. The loss of water due to dirt was around the same as obtained with the test conducted with clear water (approximately 70-75 % for $Q = 0.1$ l/s and about 50 – 53 % for $Q = 0.21/s$). The WISY fine swirl filter is illustrated with dirt in figure 22 and figure 23. The efficiency level of the filter is the lowest compared to the other filters. The filter is not suitable for all roof surfaces, some which can lead to clogging of the sieve, whereby the maintenance costs increases (see 3.3.1).



Figure 22: (left) WISY Fine swirl filter with dirt (Leaves)

Figure 23: (right) WISY Fine swirl filter with dirt (Leaves)

4 Summary

For analyzing the rainwater filter, the test arrangement was made as per Figure 1 in the experimental hall of the Forschungsstelle Wasserwirtschaft und Umwelt (fwu) at the University of Siegen. Here, the rain water supply is simulated by a processed water supply from the water tower and thus it can be continuously provided up to 2.0 l/s. For tests, the inflows of $Q = 0.1$ l/s and $Q = 0.2$ l/s were selected. These inflows are yielded from the frequent distribution of rainfalls. The rainfall data of the weather station of the University of Siegen are available in the form of 5 minute intervals. Since 1993, the data has been recorded electronically. An evaluation of the results in the years 1993 – 1997 is illustrated in Table 1 of frequency distribution:

Table 1: Evaluation of rainfall data from years 1993 to 1997

	1993	1994	1995	1996	1997	Average	Total
mm/5min	%	%	%	%	%	%	%
0.1	64.11	64.03	67.74	69.47	68.25	66.72	66.7
0.2	19.78	20.93	18.40	16.93	18.94	18.99	85.7
0.3	8.24	8.64	7.39	6.84	6.51	7.52	93.2
0.4	3.55	2.70	2.96	2.84	2.74	2.96	96.2

The table indicates that more than 96 % of rainfall occurs with an intensity of up to 0.4 mm/5 mins. Since the rainfall is collected only at certain regions, this data is valid for only Siegen. It is however to be accepted that the distribution of intensities in Germany is similar. With a roof area of 150 m², the rain yield from 0.4 mm/5 min corresponds to an inflow of maximum 0.2 l/s, which is why this maximum flow rate was selected for the tests.

In all experiments, the INTEWA hydraulic jump filter DN 100 filtered the inflow up to 100 % and there was no overflow. Thus, this filter has the greatest level of efficiency, amongst the tested filters, by filtering inflows at $Q = 0.2$ l/s (with dirt), and is in position to filter more than 96 % of the total annual rainfall. With a specially designed hydraulic jump, the filter is insensitive to dirt of large surface area (such as leaves). The cost of maintenance is low.

The 3P cartridge filter PF has a likewise high level of efficiency from 97 % to 100 %, with lesser contaminated inflows at $Q = 0.2$ l/s till the filter is wet. After that, 100 % of the inflow is filtered. Depending on the type and position of the dirt, the level of efficiency is drastically reduced. The filter performance declines with constant loss of approximately 55 % to 45 %. This filter is particularly susceptible to dirt with a large surface area (such as leaves). Leaves or similarly shaped suspended solids can remain in the filter sieve and the water will not be filtered. The maintenance costs can increase depending on the contamination, or the installation of a backflushing device may be necessary.

The performance of the filter WISY fine swirl filter WFF-100 is relatively low, with low inflows up to $Q = 0.2$ l/s and has an efficiency of 53 % to 75 %. The loss of water is extremely high at start-up and becomes lower, but does not stop completely. The performance of the filter with dirt shows only a very small decrease in the level of efficiency. This is specially designed, since dirt can also fall down even with low inflows. The filter is the largest of those tested, whereby an installation (installation in cistern?) is complicated and in addition the connected pipelines indicate a higher height offset after installation. The maintenance costs can be high depending on the dirt (for example with a high pressure cleaner, see 3.3.1).

An example for estimating the annual quantity of water loss is presented below. The input data is compiled in Table 2.

Table 2: Input data of a numerical example for estimating the annual quantity of water loss

Single family dwelling with tiled roof		
Ground area of the house	150	m ²
Average annual rainfall in Germany	800	mm
Drainage coefficient (tiled roof)	0.75	-
Annual inflow (150*(800/1000)*0,75)	90	m ³
From it 96.2 % (see above, up to Q = 0.2 l/s)	87	m ³

With the input data from Table 2 and the results from section 3, the quantity of lost water is calculated as per Table 3.

Table 3: Result of a numerical example for estimating the annual quantity of lost water

	INTEWA Hydraulic jump filter WSP 100			3P cartridge filter PF			WISY Fine Swirl Filter WFF-100		
	Filtered water		loss	Filtered water		loss	Filtered water		loss
	%	m ³	m ³	%	m ³	m ³	%	m ³	m ³
Q_{clean} = 0.1 l/s	100	87	0	99	86	1	75	65	22
Q_{clean} = 0.2 l/s	100	87	0	100	87	0	53	46	41
Q_{contaminated} = 0.2 l/s	100	87	0	44	38	48	50	43	43
				100	87	0	53	46	41

The results of the numerical example as illustrated in Table 3 indicates that the INTEWA Hydraulic jump filter WSP 100 does not show any loss of water with low inflows of up to $Q = 0.2$ l/s (corresponds to approximately 96.2 % of the annual rainfall). The 3P cartridge filter PF shows a loss of up to 48 m³/year with inappropriate position of the dirt; the WISY fine swirl filter WFF-100 shows a loss of up to 43 m³/year. These results represent only an estimate, because the input data according to Table 2 can widely vary along with the type and position of the dirt. The tests were conducted with dry filters right from the beginning of the test – that means, wet filters will have different results, but this can only be determined in a long-term experiment. Moreover, the duration of rainfall and time interval between rains is very different. Likewise, the drying time of the filter between rains will also vary. The results according to Table 3 can also be used for a rough estimation of maximum incurred loss.

The overall results of the filter comparison tests are again summarized in the Annexure (Table 4).

Siegen, on 02.08.2002

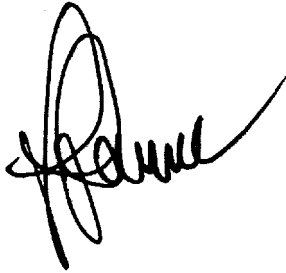

Prof. Dr. Eng. Jürgen Jensen



B. Sc. (Uni. Of Applied Sciences) Jan-Eric Kapp



B. Sc. (Uni. Of Applied Sciences) Jörg Wieland

5 Literature



INTERNET: <http://www.intewa.de> and <http://www.3ptechnik.de/> and <http://www.wisy.de>

DIN EN 12056: Gravitational water extraction facility within buildings, Part 3:
Roof drain, Planning and Design, German Edition EN 12056-3, 2000

SCHNEIDER, K.-J. ET AL. (EDITOR): Structure tables for Engineers, Werner Publishing house,
Düsseldorf, 1996

Annexure

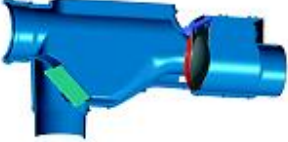
Table 4: Results of filter comparison tests

	INTEWA Hydraulic jump filter WSP 100	3P Cartridge filter PF	WISY Fine swirl filter WFF-100
Image			
Q = 0.1 l/s without dirt	100 % level of efficiency (independent of time)	Level of efficiency > 99 % (in Test, no loss after 28 mins)	Level of efficiency ≈ 75 % (Increasingly less loss, stops 1 hr after test)
Q = 0.2 l/s Without dirt	100 % level of efficiency (independent of time)	Level of efficiency ≈ 100% (only start-up loss in first few seconds)	Level of efficiency ≈ 53 % (stops 16 mins after test)
Q = 0.2 l/s With dirt	100 % level of efficiency (Type and position of the dirt is irrelevant)	Level of efficiency ≈ 44-100% (depending on the type and position and dirt)	Level of efficiency ≈ 50-53 %
Maintenance	Low maintenance cost, regardless of the type and position of the dirt.	The maintenance cost can be high depending on the type and position of the dirt.	The maintenance cost can be high depending on the type and position of the dirt.
Advantages and disadvantages	100 % level of efficiency with small inlets and up to 96 % of annual rainfall. Self cleaning only after heavy rain	Small size. If the type and position of the dirt is inappropriate → low level of efficiency with small inlets and up to 96 % of annual rainfall.	Good self-cleaning, even with low inflows. Low level of efficiency with small inlets and up to 96 % of annual rainfall. Expensive installation and height offset after installation.